

# Tank Truck

## CAP-6M

Special vehicle for refilling the ground vehicles by fuel (diesel fuel, petrol and NATO F-34 fuel) and for storing and transporting it, in case of need.



### Meets:

- the applicable EU requirements for international road transport of hazardous materials (ADR, class 3)
- requirements for safety and environment legislation requirements on utilisation of vehicles on public roads
- specific military operation requirements, in force in the Czech Army as well as in the NATO member states armies.



# VOP 025 Nový Jičín, s.p.

# Tank Truck CAP - 6M

Tank truck CAP - 6M has been designed for refilling the ground vehicles by fuel (diesel fuel, petrol and NATO F-34 fuel). It can be used not only for filling the fuel, but also for storing and transporting it, in case of need. CAP - 6M meets the applicable EU requirements for international road transport of hazardous materials (ADR, class 3) as well as safety and environment legislation requirements on utilisation of vehicles on public roads. It also meets specific military operation requirements, in force in the Czech Army as well as in the NATO member states armies.

## Basic tasks:

- Filling its own tank by fuel through its own pump
- Filling its own tank from an outside source
- Filling ground vehicles by filtered and gauged fuel from its own tank and/or other sources in the open way
- Pumping fuel between two outside sources without running the fuel through its own tank
- Pumping fuel off the ground vehicles tanks
- Emptying its own tank by self-discharging ensuring the function of emergency discharging

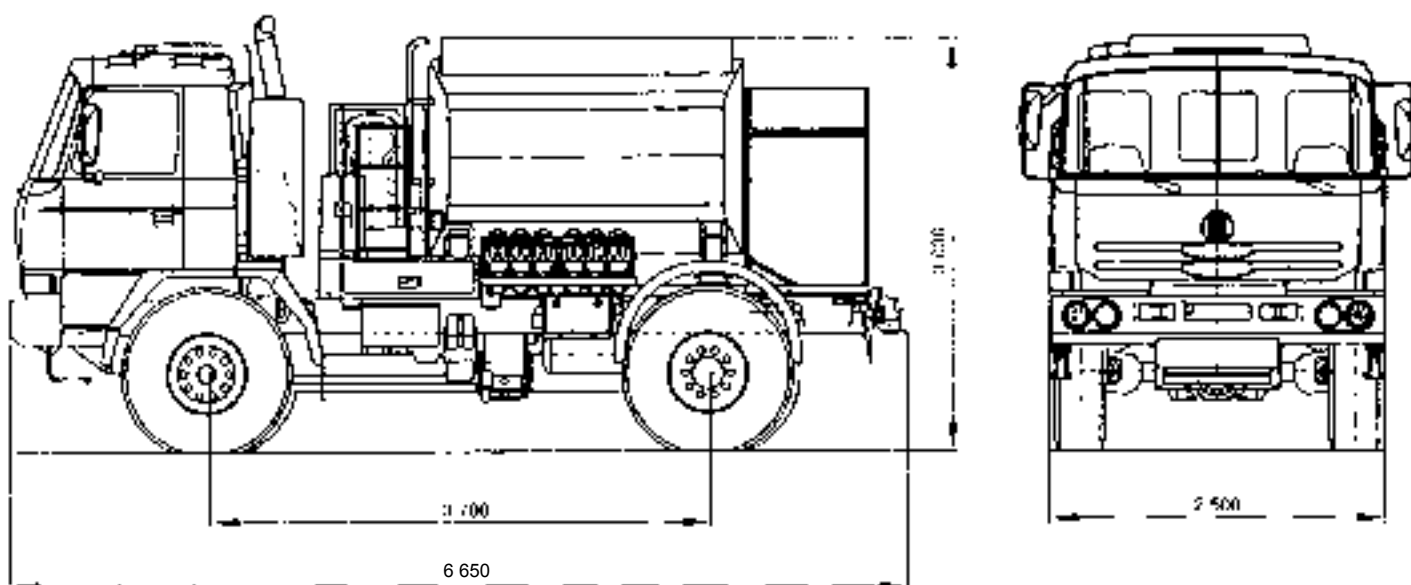

## Basic data:

- Undercarriage TATRA T 815 - 26WR 45 17 255 4x4.1/10T ARMAX
- One-chamber tank made of light alloy, capacity ..... 6 000 l
- Flow rate at delivery and/or intake ..... 380 l/min
- Flow rate in one branch at the open way (by gun) ..... 150 l/min
- Filling pump with continuous flow rate adjustment
- Delivery volumetric counter
- Vehicle engine output ..... 255 kW at 1 800 r.p.m.
- Vehicle maximum velocity ..... 85 km/h
- Gearbox ..... mechanical, 10 speed
- Brakes ..... ABS
- Suspension - torsion bars and telescopic shock absorbers in the front  
- air bellows + springs + telescopic shock absorbers in the rear



Vojenský opravárenský podnik 025  
Nový Jičín, státní podnik  
Dukelská 102, 742 42 Šenov u Nového Jičína  
Czech Republic

tel.: +420 556 783 111  
fax: +420 556 701 734  
e-mail: [marketing@vop025.cz](mailto:marketing@vop025.cz)  
[http:// www.vop025.cz](http://www.vop025.cz)